

DATE REQUIRED:

DEPENDING ON COMPLEXITY, DELIVERY TIMES MAY VARY.
 IF REQUIRED URGENTLY PLEASE CALL 0870 444 8644

ORDERING GUIDE: BDA/BDG ENGINE SYSTEMS (COIL PACK/COILS)

A) IGNITION LEAD ORDER DETAIL

Please complete in **BLOCK CAPITALS**

Dealer: _____

Your Name: _____

Address: _____

Post Code: _____

Telephone: _____ Mobile: _____

Fax: _____

LEAD TYPE REQUIRED (please tick ✓)

Copper Core (Black / Unprinted) 7mm

Electrosports 70 (Black) 7mm

Electrosports 80 (Blue) 8mm

Competition KV85 (Red) 8.5mm

If unsure, please refer to: www.magnecor.co.uk and click 'Product Information'

Or call our Technical department.

YOUR VEHICLE DETAILS

Vehicle Make/Model: _____ Year: _____

Engine Type: E.g. Honda Civic 1.6 _____

Engine Code: E.g. B16A2 _____

B) COIL PACK TYPES - Four Cylinder Examples (please tick)

Ford 1st Generation (With Hook Type Connector)

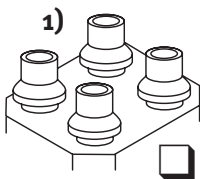

Boot Type 90° (compulsory)

Ford 2nd Generation or Valeo/Sagem/Bosch/Vauxhall/Opel etc.

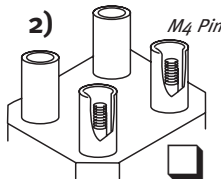

Boot Type 90° Straight

Now go to Section D)

Valeo/Sagem/Bosch/Vauxhall/Opel etc.

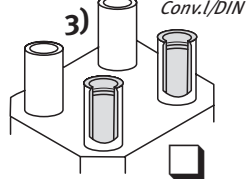

Boot Type 90° Straight

Now go to Section D)

Electromotive Ignition Etc.

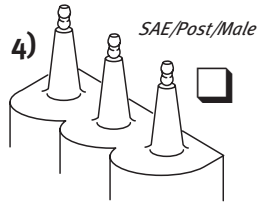

Boot Type 90° Straight

Other-Please Sketch



Boot Type: 90° Straight

For Singular type coils e.g. Mercury Outboard/Bosch Complete Section D) above

MEASURING YOUR LEADS CORRECTLY

PLEASE READ CAREFULLY TO ENSURE MEASUREMENTS ARE CORRECT.

When measuring existing ignition leads, measure from the spark plug metal terminal end to the distributor or coil metal terminal end (see diagram 1). For leads with deep boots (e.g. 16 valve engines) measure from the centre (see diagram 2). It is best to remove ignition leads from the spark plugs before measuring if the leads are difficult to reach.

Use a dressmaker's tape or alternatively lay a flexible tube/covered wire against the existing ignition lead. These can then be easily measured after the length has been established. This is the most accurate way to arrive at the correct lead lengths.

If no ignition leads are fitted to the engine, establish length by using tubing pipe or covered wire/flex or old ignition leads to make a temporary connection from the distributor to the spark plugs. Using this method will also help ascertain the best possible lead position along the entire length of the proposed ignition lead routing.

When measuring the R-100 10mm leads in particular, remember to take into account that the physical bulk of the 10mm ignition lead might necessitate longer lead lengths in order to go around corners and accessories. Also, fitting R-100 10mm ignition leads into original equipment tubes and brackets may not be possible. However, due to its exceptional flexibility the lead will squeeze into many aftermarket 8mm or larger lead separators.

C) CAPACITY: _____ NUMBER OF CYLINDERS: _____

SOHC/DOHC: _____ NUMBER OF VALVES: _____

TURBO S/CHARGED: CARB INJECTION:

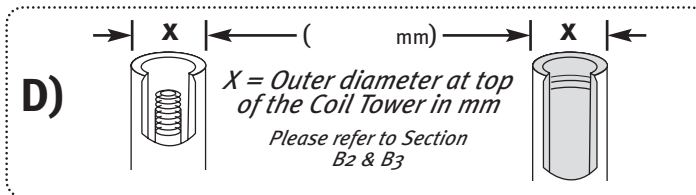

fax: **+44 (0) 870 444 6957**

International fax: **+44 (0) 1530 274624**

WHEN MEASURING YOUR CABLE LENGTHS, PLEASE MAKE ALLOWANCES FOR THE CURVATURE OF THE CABLE AS IT LEAVES THE TOP OF THE PLUG BOOT TO THE SPARK SOURCE.

Diagram 1.

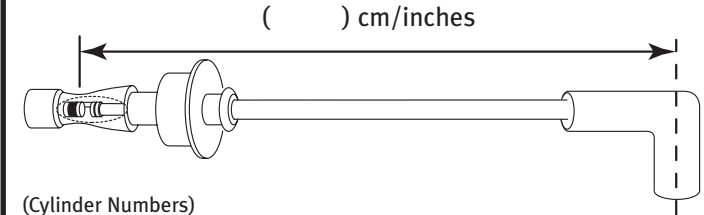

1) _____ 2) _____ 3) _____ 4) _____

OTHER RELEVANT INFORMATION: E.g. Specific Conversion Type

Diagram 2.

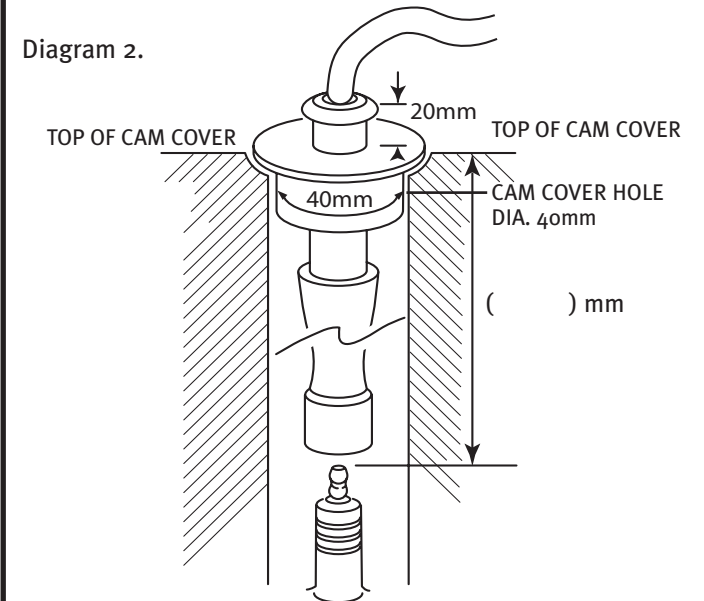

PLUG SIZE: (Please Tick)

20.8mm hex 16.0mm hex